

---

# External Siren

---

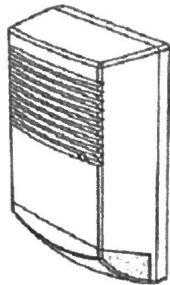

High Power Siren With  
Battery Back-up and Flashlight

INSTALLATION INSTRUCTION & USER MANUAL

## Siren Manual Installation

### Features

The siren is a new generation of professional high power acoustic siren with battery back-up and flashlight. which includes all performance and reliability for security alarm system

#### Features:

- ◆ Outdoor battery back-up siren with flashlight.
- ◆ Double housing: External-3mm plastic PC with UV, internal-0.8mm metal.
- ◆ Continuous frequency modulated sound.
- ◆ Tamper protection in 3 ways -screw or cover opening or tearing housing from the wall.
- ◆ Positive and negative alarm trigger input.
- ◆ Trigger input to active only the flashlight.
- ◆ Siren period can set as follow trigger or 3 min cutoff
- ◆ Select from the lamp or xenon
- ◆ Alarm by main power failure
- ◆ Protecting against totally battery discharge
- ◆ Plug terminal for easy installation.
- ◆ Environmental immunity

### Functional Description Alarm Trigger

The alarm can be triggered by applying high or low voltage to the "GO+" or "GO-" inputs terminals respectively. The sound and

flashlight triggered together.

Alarm siren duration depended on the trigger selector state.

◆ F.T - Follow Trigger.

◆ TMR-siren cutoff after 3 minutes, this state is recommended in order to avoid violation of any local regulations.

#### Flash Trigger:

The flashlight can be triggered by applying "low" level to "FL-" terminal. Flashlight duration is not limited and the time of flashlight is set by control panel-as long as trigger available the flashlight will be active.

#### Tamper:

The tamper is normally closed while the housing is closed with the screw, so in this state the tamper terminals are shorted (0 ohm).The tamper will open while opening the screw the tamper socket to the wall properly.

#### Power Failure:

On power failure the siren and flashlight are triggering, until power supply is restored or time out (5 minutes) expires.

#### Battery Protection:

The siren is supplied with protection against totally battery discharge by cutting off the siren, when voltage level falls down to less than 8VDC.

### Installation instructions

1. Choose the mounting location for the siren-the wall must be even and free of hole and excessive protrusions.
2. Mark and drill 5 holes with help of attach drill pattern plate (4 holes for the housing based and 1 for the tamper).

*Note: Take a consideration about the wires inputs in the housing base.*

3. Open the siren housing(1 screw on the front),fig1 and remove the metal cover (2 screws),fig2
4. Unplug the terminal 5 on the siren driver
5. Mount the siren housing on the wall.
6. connect the wires to the terminal 5

*Important: Cut off the power before you make the connection*

7. Plug the terminal to your drive board.
8. Power on the system and check that its function properly
9. Connect the back-up battery

*Important: keep attention the polarity of the battery; a reverse polarity can cause damage of the driver circuit.*

10. Mount the metal cover by 2 screws
11. Close the housing by 1 screw.

### Terminal Block Connection

Terminal 1-Marked "FL-"trigger for the flashlight connect it to output in the alarm system, Active while the input is low.

Terminal 2- Marked "Go+" trigger for the siren and the flashlight, Active while the input is high.

Terminal 3-Marked "GO-" trigger for the siren and flashlight, active while the input is low.

Terminal 4-Marked the "GND" connect to the ground of the control unit.

Terminal 5-Marked "+12V" connect to a positive voltage output of the 13.6-14.2VDC source (usually from the alarm control unit).

Terminal 6&7-Marked "Temper" if a tamper function is required connect these terminals to a 24-hour normally closed the protective zone in the control unit, if the front cover of the siren is opened or siren box is tearing from the wall, an immediate alarm signal will be sent to the control unit

<b>Siren Specification</b>	
SPL	128db
Fundamental Frequency	1850Hz
Siren Tone	Yelp
Frequency Range	1300-2400Hz
Flashlight	Lamp 12VDC/5W
Power supply Voltage	13.8-14.2VDC
Charge Current Limit	250mA
Current Consumption(Speaker and strobe)	Standby:8mA Alarm 1600mA@13.8VDC
Maximum Power	50W(peak)
Trigger Level	Trigger Low=Max.1VDC Trigger High=Min.9VDC
Siren Alarm Period	F.T-Follow trigger TMR-3 min
Input Impedance(Alarm/Flash/Trigger)	1K ohm
Tamper Switch	N.C 28VDC Maximum current 0.1A-open when cover is removed
Backup Battery	Rechargeable Lead Acid Battery 12VDC up to 1.2Ah
Low Battery Level	8VDC+/-0.3VDC
Material	External Box: ABS(3mm Thickness) Internal cover: metal(0.8mm thickness)
Dimensions of Unit	L=270mm*W=193mm*H=100mm
Weight(without battery)	1.85Kg
Operating Temperature Range	-30 to +60°C
Case Protection Level	Water splash resistant Plastic PC with UV Protection Conformal coated circuit board

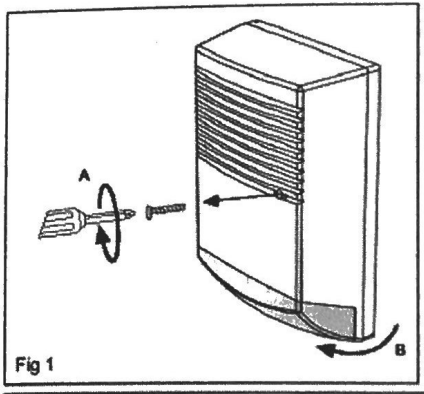

Fig 1

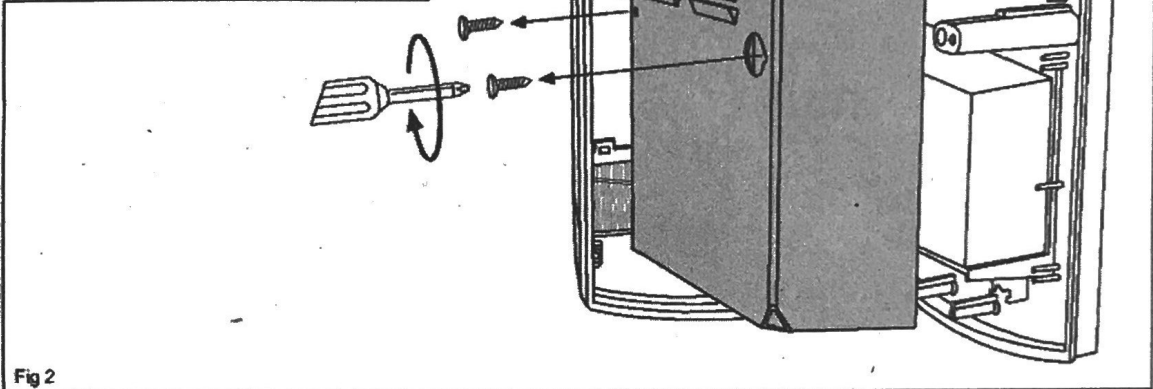

Fig 2

**Siren Includes:**

- 1-Horn      4-Tamper
- 2-Lamp     5-Terminal Block
- 3-Battery   6-Connector

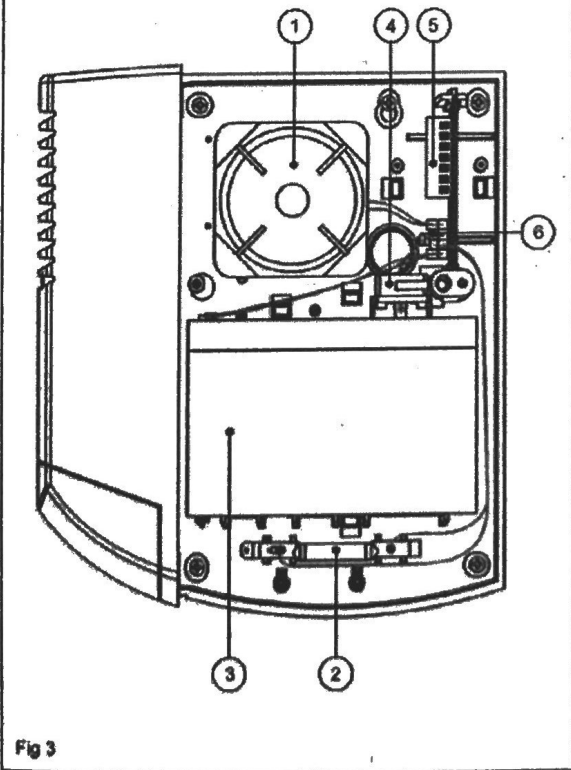

Fig 3

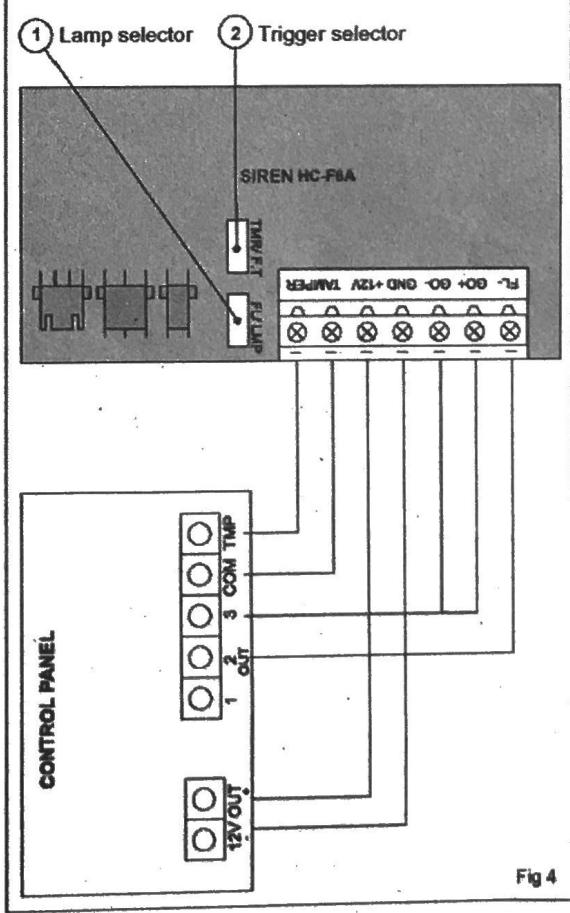

Fig 4