

The RE-4K four-channel remote control set enables electrical equipment to be remotely controlled by means of radio transmitters (remote keys). The remote control set can work with up to 340 remote keys. **The RE-4K only supports SATEL-manufactured remote keys.**

Interaction of the RE-4K with security systems is facilitated by inputs which provide information on the system status. They make it possible to easily organize signaling of arming / disarming, as well as of alarm clearance.

The design is based on the components of Microchip Technology Inc. which use the KEELOQ[®] code-hopping technology for transmission between the transmitter and the receiver. It ensures both security of use and resistance to spurious control signals coming from other devices.

1. Description of electronics board

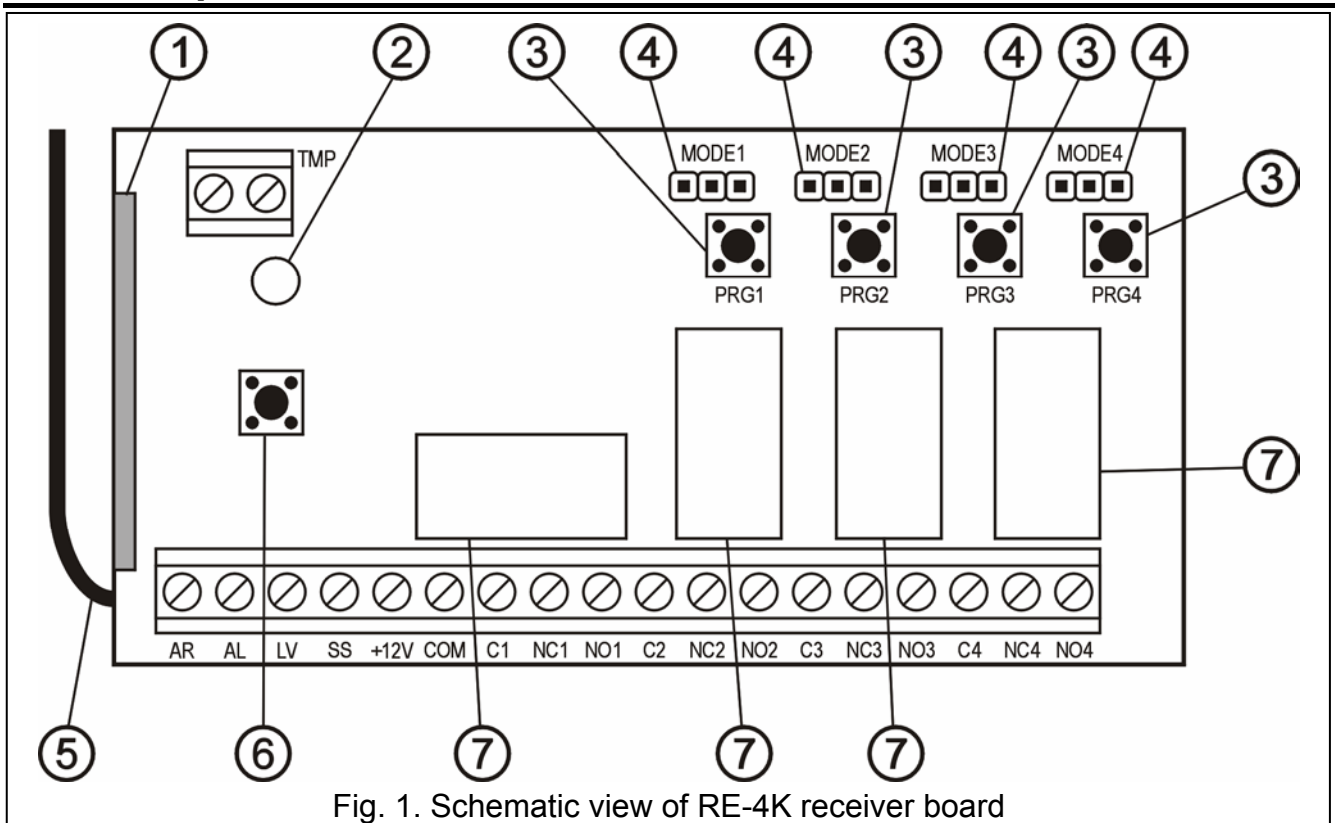

Fig. 1. Schematic view of RE-4K receiver board

Legend:

- 1 – receiver;
- 2 – LED indicator;
- 3 – programming buttons (PRG1 – channel 1; PRG2 – channel 2; PRG3 – channel 3; PRG4 – channel 4);
- 4 – pins to program the operating mode of relays (MODE1 – channel 1; MODE2 – channel 2; MODE3 – channel 3; MODE4 – channel 4);
- 5 – antenna;
- 6 – tamper contact;
- 7 – relays.

Description of terminals:

- AR** – information signal input - security system status (armed / disarmed);
 - AL** – information signal input - alarm;
 - LV** – signal output - low battery in remote key (OC); the output activates when the receiver detects low voltage in the remote key battery and remains active until a remote key with good battery is used (it can be used e.g. to report a trouble in the security system);
 - SS** – siren control output (OC);
 - +12V** – supply voltage input (direct voltage from 9V to 16V);
 - COM** – common (ground);
 - Cn** – common terminal of relay;
 - NCn** – normally closed terminal of relay;
 - NO_n** – normally open terminal of relay;
 - TMP** – tamper contact terminals.
- } n – relay (channel) number

The two-color **LED** indicates the module operating status and facilitates programming of the receiver parameters:

- green light – normal operating mode;
- red light – receiving signal from remote key in normal operating mode;
- green blinking light – waiting for the first press of the remote key button when entering new remote key into the receiver memory;
- red blinking light
 - waiting for the second press of the remote key button (when entering new remote key into the receiver memory);
 - the remote key battery is exhausted (after pressing the remote key button normal operating mode);
 - clearance of the receiver memory;
- alternately blinking red and green light – programming the monostable relay ON time;
- blinking by the sequence: red color, green color, extinction – started mode of programming from the computer.

The programming buttons **PRG1 to PRG4** allow:

- entering remote keys into the receiver memory;
- programming the monostable relay changeover time for the given channel.

Additionally, the **PRG1 button** makes it possible to clear the receiver memory.

2. Installation

The receiver electronics board includes components sensitive to electrostatic discharges. These electrostatic discharges should be removed prior to installation. Also, touching the receiver board components should be avoided in the process of installation.

The RE-4K is mounted in a plastic housing. When closing the housing, be particularly careful so that the programming button is not pressed in by the cables.

It is recommended that the manufacturer specified batteries be used in the remote keys. The battery status must be periodically checked (e.g. by noting how the LED on the receiver board lights when the remote key button is being pressed) and, if necessary, the used batteries must be replaced by new ones.

Notes:

- Do not discard the used batteries. They should be disposed of as required by the existing regulations (European Union Directives 91/157/EEC and 93/86/EEC).
- Making any construction changes or unauthorized repairs is prohibited. This applies, in particular, to modification of assemblies and components.

3. Programming

The RE-4K can be programmed by means of programming buttons or a computer with DLOAD10 program installed. The **DLOAD10 program is available on web-site www.satel.pl**. The program offers more advanced operation of the RE-4K. It allows edition of the list of remote keys by their unique serial numbers, deletion of individual remote keys already entered in the system, and assignment of user names to remote keys.

3.1 Starting communication with DLOAD10 program

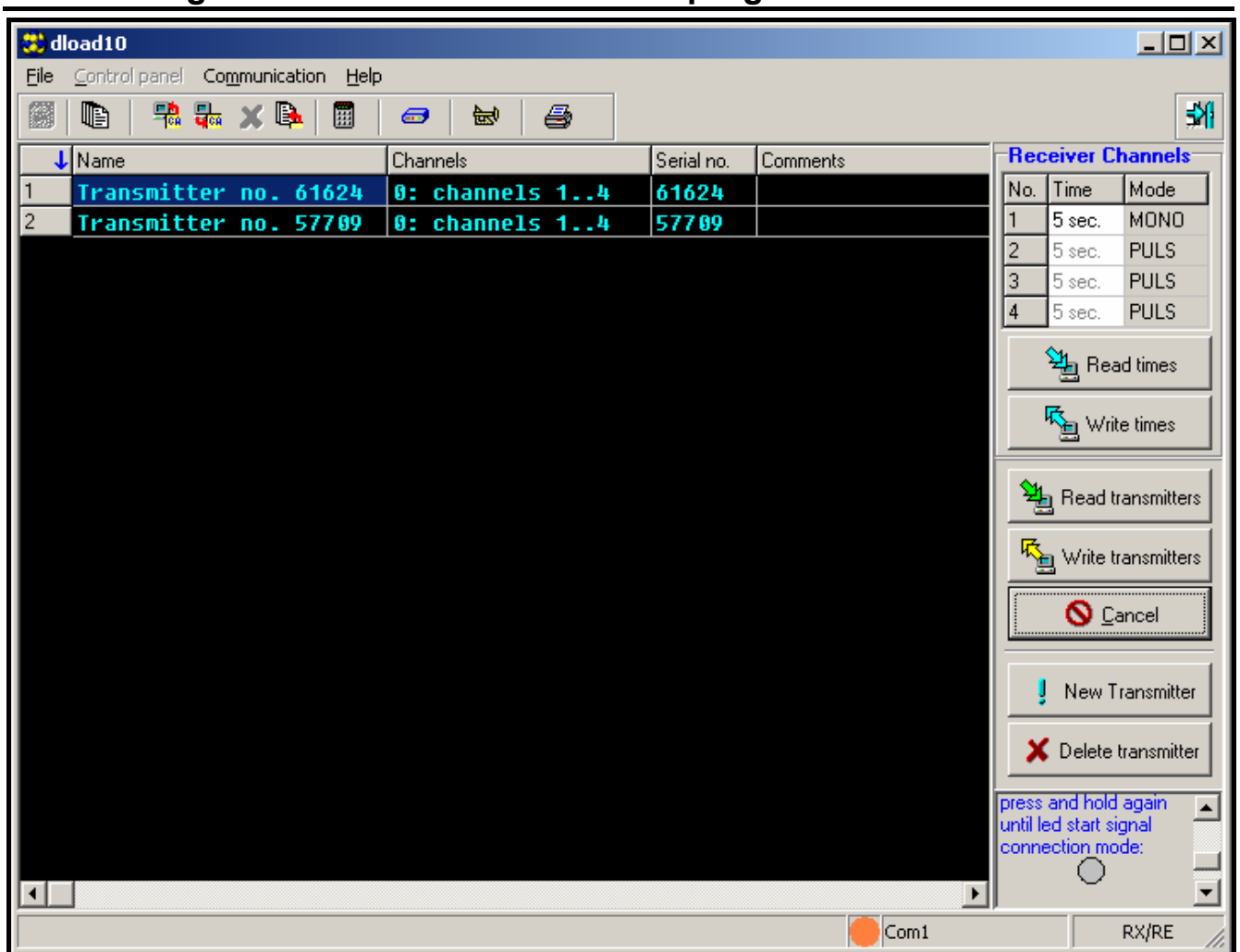

Fig. 2. Management window for RK-4K in the DLOAD10 program.

In order to start the RE-4K communication with the DLOAD10 program, you should:

1. Connect the receiver to the computer by means of the RS-CA5/6/R-2/4K cable (for connection details please see the instructions attached to the RS-CA5/6/R-2/4K cable).
2. Start the DLOAD10 program in the computer (the program access is protected by password, which is **1234** by default and can be changed to any sequence of 16 characters - digits from 0 to 9 and letters from A to F can be entered.).
3. Enter the "Communication" menu, select the "Configuration" item, and indicate the computer port, the receiver is connected to.

4. Start the computer programming mode in the receiver, following the procedure below:
 - press and hold down the PRG4 programming button until the LED changes for a while the color of its light to red;
 - release the PRG4 button momentarily, then press it again and hold down until the LED starts blinking according to the sequence: red color, green color, extinction.

Note: *If communication with the DLOAD10 program fails to be established within one minute, the receiver will return to its normal operating mode.*

5. In the DLOAD10 program, select "New device" in the "File" menu, and then the "RX-2K/RX-4K/RE-4K". The remote control sets management window opens. Click on the "Read transmitters" button to open the list of remote keys already entered into the receiver.

3.2 Adding remote keys

The receiver offers extended features for remote keys configuration. It makes it possible to control either all channels, or selected ones only.

3.2.1 Adding remote keys by means of programming buttons

The number of channels the remote key will be able to operate depends on the number of button used for entering the remote key into the receiver memory. For example, if the T-4 remote key is entered with the use of the **PRG2** button, the remote key will be able to operate the channels **2, 3** and **4**. The channel 1 will be unavailable to it. The active buttons of the remote key will be 1, 2 and 3, while the button 4 will be inactive. Shown in the table below are channels available in the remote key, depending on which programming button was used to enter the remote key.

		Remote key available channels	Remote key button No.			
			1	2	3	4
Programming button used	PRG1	1...4	1	2	3	4
	PRG2	2...4	2	3	4	
	PRG3	3...4	3	4		
	PRG4	4	4			

Table 1. Channels available in the remote key (blank fields mean inactive buttons).

To enter remote key into the receiver memory, you should follow the procedure below:

1. Press the selected programming button – the LED starts blinking green.
2. Press any button on the remote key – the LED starts blinking red.
3. Press again the remote key button – the LED light changes to steady green. The remote key has been entered into the memory.

Note: *If the memory is already full or the remote key is incorrect (from another manufacturer), the receiver will return to its normal status after the first press of the remote key button.*

3.2.2 Adding remote keys by means of DLOAD10 program

In order to enter a remote key into the receiver memory with the DLOAD10 program you should:

1. Press the "New transmitter" button. The new remote key adding window opens.

2. According to the displayed command, press any button of the remote key.
3. According to the displayed command, press the remote key button again.



Fig. 3. Window for adding new remote keys in the DLOAD10 program.

4. Select, how many channels is the remote keys to operate (compare Table 1).
5. If required, enter the remote key name.
6. Press the "Next" button to add another remote key, or the "End" button to close the window. The new remote keys will now be included in the list of operated remote keys with the annotation: "New, to write".
7. Press the "Write transmitters" to save the entered changes. If the changes are not saved, the receiver will not be able to handle the new remote keys.

Changing the number of channels used by the remote key as well as editing its name can be done at any moment by means of DLOAD10 program.

3.3 Removing remote keys

Individual deletion of remote key is only possible by using the DLOAD10 program. The programming buttons make it only possible to erase full content of the receiver memory, i.e. also the remote key entered into it.

3.3.1 Clearance of receiver memory

In order to clear the receiver memory, you should:

1. Press and hold down the PRG1 programming button until the LED changes for a while the color of its light to red (which will occur after approx. 3 seconds).
2. Release the PRG1 button momentarily, then press it again and hold down until the LED starts blinking red (which will occur after approx. 3 seconds), signaling thereby that the receiver memory is being erased.

When the LED starts lighting steadily green again, the receiver is ready for programming new remote keys.

3.3.2 Removing remote keys by means of DLOAD10 program

To remove the remote key from the receiver memory you should:

1. Click on the remote key to be removed on the list of remove keys.
2. Press the "Delete transmitter" button and confirm selection in the pop-up window.
3. Press the "Write transmitters" button to save the entered changes. If the changes are not saved, the receiver will continue handling the remote key that were to be removed.

3.4 Programming relay operating mode

The relay can work in one of the three modes, depending on how the jumpers are set on pins.

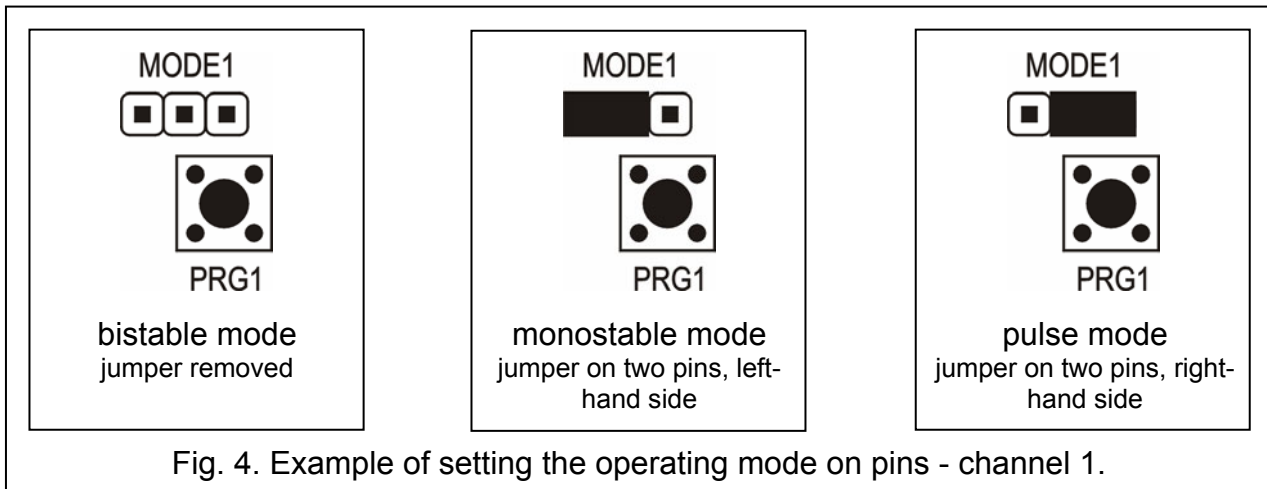

Bistable mode (see Fig. 4) – each press of remote key button changes the relay status to the opposite one.

Monostable mode (see Fig. 4) – relay activated for a preset time.

Pulse mode (see Fig. 4) – relay activated for the time when remote key button is pressed.

3.4.1 Programming monostable mode on-time

By default, the monostable mode on-time is preprogrammed at 5 seconds. It can be changed by the user and set within the range of **1 to about 250 seconds**.

In order to enter the new monostable on-time for the selected channel (relay) by means of the programming buttons you should:

1. Press the selected channel programming button twice – the LED will go out.
2. Press one of the active remote key buttons (see ADDING REMOTE KEYS) - the LED will start blinking green and red.
3. Having measured off the required time, press the remote key button again – the LED light will turn into steady green.

You can change the monostable mode on-time in the DLOAD10 program by entering from the keypad a new value for the selected channel. To save the entered changes in the receiver memory, press the "Save times" button.

4. Interaction with the security system

Using the remote key button you can arm / disarm the security system or trigger / clear an alarm. To be able to do so, connect the terminals of relays selected for control to the suitably preprogrammed control panel zones.

The SS receiver output can signal arming / disarming / disarming and alarm clearing by means of the remote key. In order to ensure such signaling, it is necessary to connect suitably preprogrammed control panel outputs to the AR, AL inputs (the armed mode information output to the AR input, and the output signaling alarm to be canceled - to the AL input). The AR and AL inputs are monitored for 4 seconds since the remote key was used. If there is a change in the status of the monitored inputs during that time, the SS output will trigger suitable signaling. The signaling is effected by shorting the SS output to ground for the pulse duration (0.16 second). The event can be identified by the number of pulses:

- 1 pulse – arming;
- 2 pulses – disarming;
- 4 pulses – disarming plus alarm clearing.

The SS output can be used e.g. to control a siren. Permissible current-carrying capacity of the SS output is 500mA.

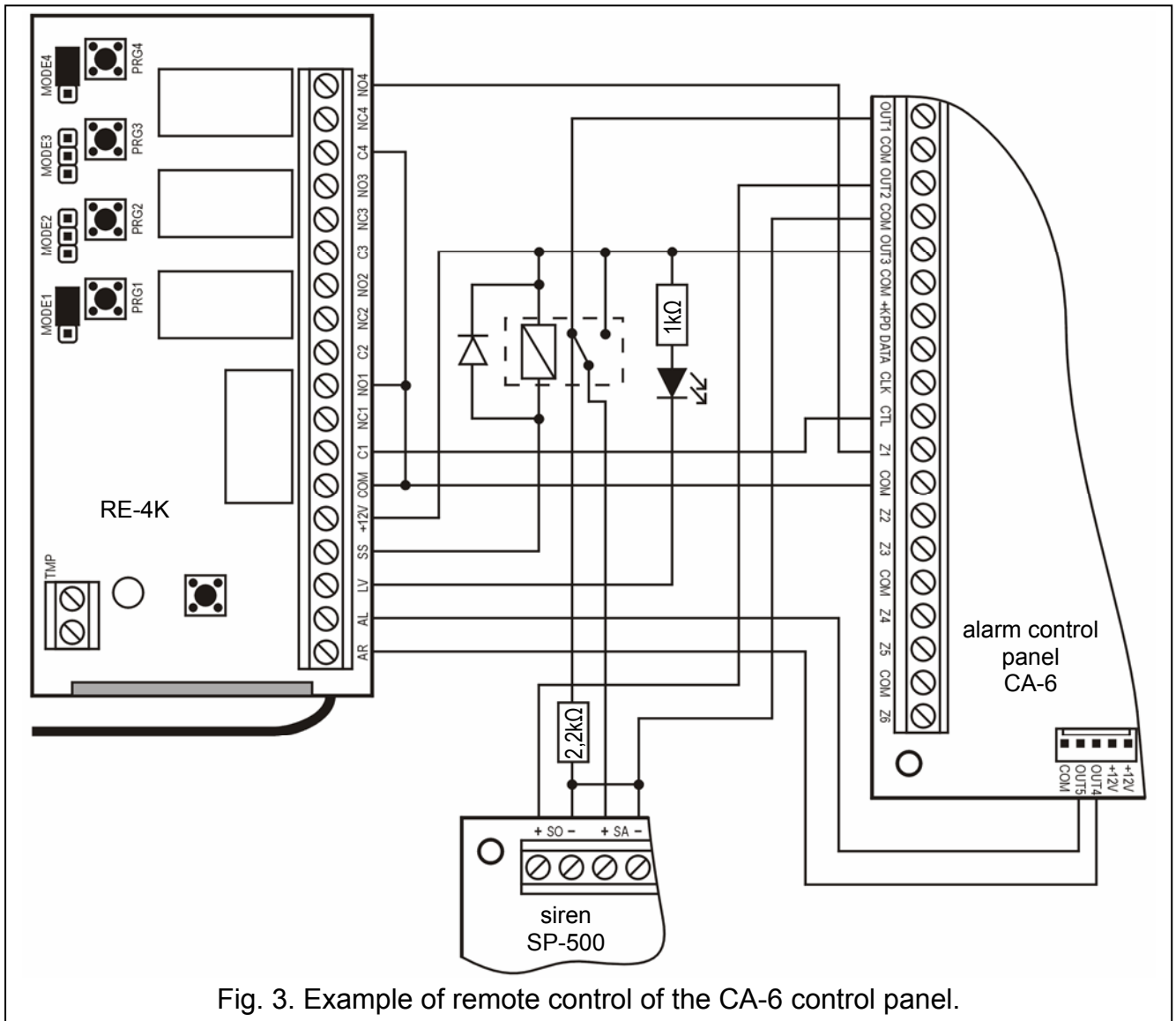

Fig. 3. Example of remote control of the CA-6 control panel.

In the presented example, the channel 1 (relay 1) controls the control panel armed mode, while the channel 4 (relay 4) triggers the silent PANIC alarm. These relays operate in the pulse mode (jumpers suitably set on the MODE1, MODE4 pins) and feed the common ground (0V) to the CTL, Z1 zones of the control panel. The remote key must be entered into the receiver memory by means of the PRG1 button. In order to arm / disarm the system, press and hold down the button No. 1 on the remote key. To trigger the panic alarm, press the button No. 4. In order to avoid the risk of accidental alarm triggering, set a suitable sensitivity of the Z1 zone in the control panel (e.g. 3 seconds).

The SS output controls the relay, which supplies +12V voltage to the +SA siren input and, consequently, generates a sound signal. At the moment of changeover, the OUT1 control panel output remains connected via the 2.2kΩ resistor to the common ground in the siren, thus ensuring presence of the load on the OUT1 output, as well as cabling control when armed/disarmed states are being signaled. The resistor should be installed inside the siren housing.

The figure shows also a simple solution to low-battery indication in the remote key (the LED is connected to the LV input).

The CA-6 control panel makes it possible to program the following parameters:

- OUT1 - alarm on for preset time (+12V during the output on-time);
- OUT2 - alarm on until canceled (+12V during the output on-time);
- OUT3 - power supply output (+12V);

- OUT4 - armed mode indicator (type OC output – program +12V during on-time)
 OUT5 - alarm on until canceled (type OC output – program +12V during on-time);
 CTL - arming/disarming one or both partitions (FS 125);
 Z1 - 24H silent zone (using the remote key button No. 4 will send a code to the monitoring station).

5. Technical data

Range in open area	up to 100m (an obstacle between the transmitter and the receiver will reduce the device operating range)
Number of controlled outputs	4
Supply voltage, rated	12V DC \pm 15%
Current consumption, minimum	approx. 13mA
Current consumption, maximum	approx. 65mA
Current-carrying capacity of relay contacts	2A
Adjustment range of changeover time in monostable mode	1 to 255s
Maximum voltage of relay contacts	24V DC
Current-carrying capacity of LV (OC) output	50mA
Current-carrying capacity of SS (OC) output	500mA
Operating frequency range	433.05 – 434.79MHz
Operating temperature range, receiver	-10 to +50°C
Operating temperature range, transmitter (remote key)	-20 to +55°C
Housing dimensions	72x118x24mm
Type of remote key battery, T4	23A 12V

DECLARATION OF CONFORMITY		CE 1471
Product: RE-4K – remote control set	Manufacturer: SATEL spółka z o.o. ul. Schuberta 79 80-172 Gdańsk, POLAND tel. (+48 58) 320-94-00 fax. (+48 58) 320-94-01	
Product description: A set of remote control set with coded transmission, having 4 controlled outputs, operating in frequency band 433.05MHz – 434.79MHz. The set includes a +12V DC supplied receiver and battery supplied remote keys (transmitters), type T-4. The device enables low-voltage equipment to be controlled, including alarm control panels.		
This product conforms to the following EU Directives: R&TTE 1999/5/EC		
This product meets the requirements of harmonized standards: R&TTE: EN 300 220-1: v.1.3.1; EN 300 220-3: v.1.1.1; EMC: EN 301 489-1: v.1.4.; EN 301 489-3: v.1.4.1 LVD: EN60950-1:2001		
Notified body taking part in conformity evaluation:		Identification No.: 1471
Gdańsk, Poland 2005-08-12	Head of Test Laboratory: Michał Konarski	